

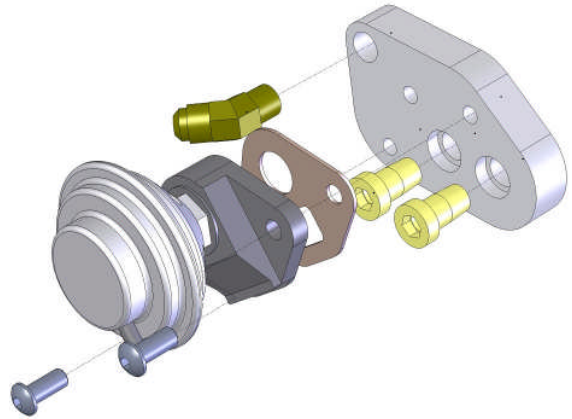

MiniRam EGR Kit 2.EGR500

Parts List

- EGR block
- EGR valve
- EGR gasket
- 1/4" NPT block bolts (2)
- 5/16" S.S. valve bolts (2)
- 3/8" pre-bent feed tube w/ flare nuts
- 45° -6 fitting
- 90° -6 fitting
- 1/4" NPT header bung
- 1/8" vacuum fitting
- 1/8" NPT plug



1. Using a 3/8" Allen, bolt the EGR block to the right side vacuum ports, making sure the block is tight and straight and the bolt with the 1/8" pipe thread must be in the forward most port. (Use Teflon sealer or tape on threads)
2. Next, bolt on the EGR valve and gasket with the two S.S. bolts
3. Now, install the 3/8" feed tube to the 45° fitting and mark the place to weld the header bung to the exhaust. (if you have a set of TPiS headers, the bung is already there)
4. After the bung is in place thread in the 90° fitting with Teflon on the threads. Now you can gently bend and twist the feed tube till you get the desired fit. (Keep feed tube from making contact with anything, as the tube will get very hot when the EGR is in use.)
5. Install either the 1/8" vacuum fitting or plug in the forward most block bolt using Teflon thread sealer or tape.
6. Attach the EGR valve vacuum port to your OE style EGR solenoid and the solenoid to manifold vacuum. Start engine and check for vacuum leaks.



TPiS, Inc.
4255 Creek Rd. Chaska, MN 55318
(952) 448-6021 Fax (952) 448-7230
www.tpis.com